

# Alliance

## 6L INDOOR GRILL AIR FRYER

INSTRUCTION MANUAL



**1750W**



Adjustable  
time control



Adjustable  
temperature  
control



Easy to  
clean  
and use

AHA-AF55003D

## SPECIFICATIONS

---

Power Supply	220~240V, 50 ~60Hz
Rated Power	1750W
Capacity (Cooking Pot)	6L
	3.9L (Basket)
Temperature Range	40°C-265°C
Time Range	1min-12hr
Weight	8.9 kg
Dimensions	347(L) x 415(W) x 262(H)mm



# READ AND SAVE THESE INSTRUCTIONS

---

## IMPORTANT SAFEGUARDS

---

Follow basic safety precautions when using your air fryer grill.  
Read all instructions.

### Key Safety Points

- **Do not** touch hot surfaces. To open, use handle and a heat-resistant glove or oven mitt to avoid touching the surface of the grill.
- The outside of the grill, including the lid, is hot during and after use.
- **Always** use heat-resistant gloves, pads, or oven mitts when handling hot materials, and when placing items in or removing items from the grill, including accessories or containers.
- **Do not** block any ventilation openings. Keep hands and face clear of vents at all times.
- **Do not** use third-party replacement parts or accessories, as this may cause injuries.
- **Do not** use outdoors.
- **Do not** place the grill or any of its parts on a stove, near gas or electric burners, or inside a heated oven.
- Be extremely cautious when removing a tray or basket if it contains hot oil, grease, or other hot liquids.
- **Do not** clean with metal scouring pads. Metal fragments can break off the pad and touch electrical parts, creating a risk of electric shock, as well as damage ceramic coating on accessories.
- Clean the cooking pot after using. Accumulated grease and crumbs can overheat and catch fire.

### General Safety

- When the grill is not in use, and before cleaning, press  to turn it off, then unplug from outlet. Allow to cool completely before putting on or taking off parts.
- **Do not** immerse the housing, cord, or plug in water or liquid.
- Closely supervise children near the grill.
- **Do not** use your grill if it is damaged, not working, or if the cord or plug is damaged.
- **Do not** store anything on top of your grill while it is operating. **Do not** store anything inside your grill other than recommended accessories.
- **Do not** operate with a separate remote-control system.
- **Only** use as directed in this manual.
- Not for commercial use. Household use **only**.

## READ AND SAVE THESE INSTRUCTIONS

---

- This grill is not intended for use by persons (including children) with reduced physical, sensory, or mental capabilities, or lack of experience and knowledge, unless they have been given supervision or instruction concerning use of the grill by a person responsible for their safety.
- Supervise children when they are near the grill.
- Children should not clean or perform maintenance on the grill without supervision.

### While Cooking

- An **air fryer** grill works with hot air **only**. **Never** fill the cooking pot with oil or fat.
- **Do not** place oversized foods or metal utensils into your grill.
- **Do not** place paper, cardboard, or non-heat-resistant plastic into your grill, or any materials which may catch fire or melt.
- To avoid overheating, **do not** use metal foil in the grill unless directed. Use extreme caution when using foil, and **always** fit foil as securely as possible. If the foil contacts the grill's splatter guard or heating element, this can cause overheating and risk of fire.
- **Never** put baking or parchment paper into the grill without food on top. Air circulation can cause paper to move and touch the splatter guard or heating element.
- **Always** use heat-safe containers. Be extremely cautious if using containers that aren't metal or glass.
- Keep your grill away from flammable materials (curtains, tablecloths, walls, etc.). Use on a flat, stable, heat-resistant surface away from heat sources or liquids.
- Immediately turn off and unplug your grill if you see dark smoke coming out. White smoke is normal, caused by heating fat or food splashing, but dark smoke means that food is burning or there is a circuit problem. Wait for smoke to clear before opening the lid.
- **Do not** leave your grill unattended while in use.

# READ AND SAVE THESE INSTRUCTIONS

---

## Power & Cord

- **Do not** let the power cord (or any extension cord) hang over the edge of a table or counter, or touch hot surfaces.
- Your grill should **only** be used with **220-240V, 50-60Hz** electrical systems. **Do not** plug into another type of outlet.
- If the power supply cord is damaged, it must be replaced by qualified persons in order to avoid an electric or fire hazard.

## Electromagnetic Fields (EMF)

This indoor grill complies with all standards regarding electromagnetic fields (EMF). If handled properly and according to the instructions in this user manual, the appliance is safe to use based on scientific evidence available today.



# GETTING TO KNOW YOUR INDOOR GRILL

Your Air Fryer Grill uses rapid 360° air circulation technology to cook with little-to-no oil for crispy, delicious food with up to 85% less fat than traditionally deep-fried foods. With 6 convenient cooking functions, and ceramic-coated accessories, the Air Fryer Grill is the star of your kitchen.

## Indoor Grill Diagram

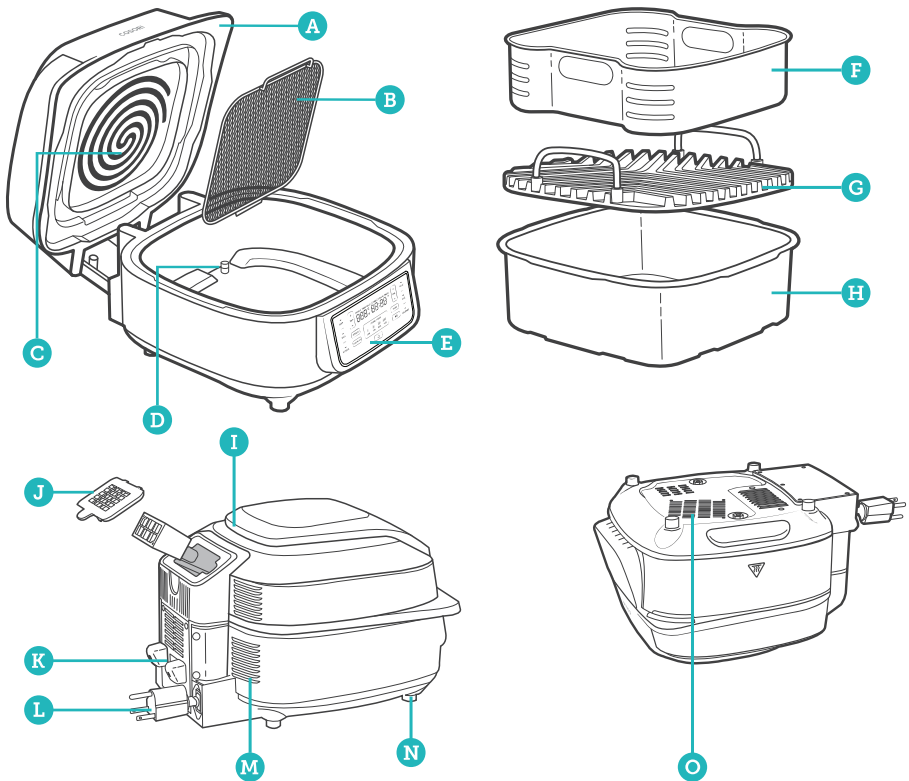

- A. Top Handle
- B. Splatter Guard
- C. Heating Element
- D. Cooking Pot Interlock
- E. Control Panel
- F. Basket
- G. Grill Grate
- H. Cooking Pot
- I. Upper Air Intake
- J. Filter Cover
- K. Oil Collector
- L. Power Cord
- M. Lower Air Outlet
- N. Feet
- O. Bottom Air Intake

# DISPLAY

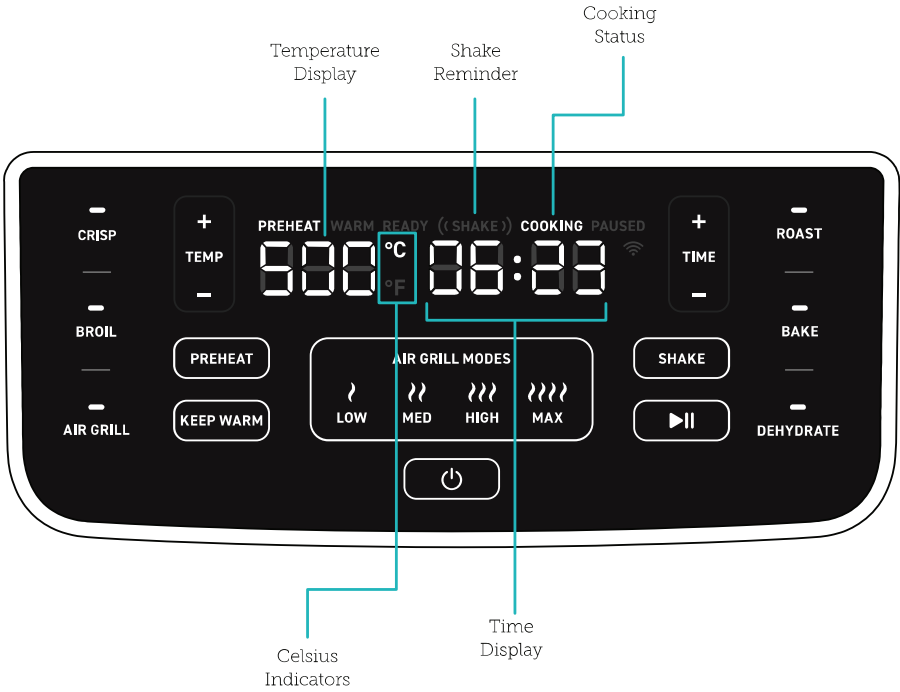

# CONTROLS

---

## POWER Button

- Press to turn the grill on/off.
- While the grill is cooking or paused, press to cancel cooking. The grill will return to standby.
- Press and hold for 15 seconds to reset the grill to factory settings. This will restore all default cooking function settings.

## START/PAUSE Button

- Press to start or stop a cooking function.
- Press to resume cooking after pausing.

## SHAKE Button

- Press to add or remove a Shake Reminder.
- The Shake Reminder will appear halfway through the remaining cooking time. The grill will beep, and “(SHAKE)” will blink on the display. This will repeat every 60 seconds and turn off after 2 minutes if there is no activity.
- The Shake Reminder will also turn off if you open the lid to flip food or press the Shake button.
- The Shake Reminder cannot be added to the Dehydrate function.
- For more information on shaking, see **Shaking Food** (page 22)

## TIME Button

- Press + or – to adjust cooking time.
- Time will adjust in increments of +/- 5 minutes.

## TEMP Button

- Press + or – to adjust temperature in increments of +/- 5°C
- Press and hold to adjust in increments of +/- 15°C
- Press and hold both + and - for 5 seconds to switch between Fahrenheit and Celsius.

## AIR GRILL Button

- Press to select the Air Grill function.
- Press repeatedly to cycle through heat settings.

## PREHEAT Button

- Press to add or remove preheat before cooking.
- Preheat cannot be used with the Dehydrate function.
- Preheat time is calculated automatically.

## KEEP WARM Button

- Press before or during cooking to select the Keep Warm function.
- If selected, Keep Warm function will begin after cooking time is over.
- Keep Warm cannot be added to the Dehydrate function.

## Cooking Functions

Crisp	Air Grill (Low, Medium, High, Max)	Roast	Broil	Bake	Dehydrate	Preheat	Keep Warm
-------	---	-------	-------	------	-----------	---------	-----------

## Time Increment Chart

<b>Crisp, Broil, Roast, Bake</b>		
Below 60 minutes	Press once	+/- 1-minute increments
	Press and hold	+/- 15-minute increments
1–2 hours	Press or press and hold	+/- 15-minute increments
<b>Dehydrate</b>		
Below 60 minutes	Press once	+/- 5-minute increments
	Press and hold	+/- 30-minute increments
1–2 hours	Press or press and hold	+/- 30-minute increments

## Temperature Increment Chart

<b>Crisp, Broil, Roast, Bake, Air Grill (Low, Medium, High, Max), Dehydrate</b>	<b>Temperature Increment</b>
Press once	+/- 5-minute increments
Press and hold	+/- 15-minute increments

### Note:

- If the grill is inactive for 10 minutes, it will turn off automatically.
- When you open the lid during cooking (such as to shake food), the grill will pause cooking automatically. When you close the lid, the grill will resume cooking.
- When the grill is plugged in and turned off, it will remember its previous settings.

# BEFORE FIRST USE

## Setting Up

1. Remove all packaging around and inside the grill, including any temporary stickers.
2. Place on a stable, level, heat-resistant surface, away from anything that can be damaged by steam or heat (such as walls or cupboards).

**Note:** Leave 7 inches / 18 cm of space behind and 8 in / 20 cm of space above the grill. [Figure 1.1]

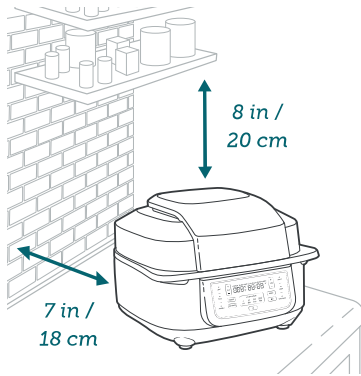

Figure 1.1

3. Wash the basket, cooking pot, and grill grate thoroughly, using either a dishwasher or a non-abrasive sponge.
4. Wipe the inside and outside of the grill with a slightly moist cloth. Dry with a towel.
5. Wipe the outside surface of the smoke filter. Dry with a towel.

## Test Run

A test run will help you become familiar with your grill, make sure it's working correctly, and clean it of possible residues.

1. Make sure there is no food or packaging in the grill and plug it in.
2. Place the splash guard on the underside of the lid, below the heating element.
3. Place the cooking pot in the base, then place the grill grate on top of the cooking pot.
4. Press **POWER**, then press **MAX**.
5. Press **START/PAUSE** to begin heating. The **START/PAUSE** button will light up, and the display will show the timer counting down.
6. The grill will stop heating and beep several times when finished.

### Note:

- You may notice a slight smell during this process. This is normal for a new grill.
- The outside of the grill will be hot during and after use. To open, use handle and a heat-resistant glove or oven mitt to avoid touching the surface of the grill.

# COOKING WITH YOUR INDOOR GRILL

---

## CAUTION:

- The outer surface of the grill, including the lid, is hot during and after use. Temperature may be over 100°C. **Do not** touch hot surfaces. Use handle.
- **Always** use heat-resistant gloves, pads, or oven mitts when handling hot materials, and when placing items in or removing items from the grill.
- **Do not** fill the cooking pot with liquid or fat. This may cause damage to the grill.
- To avoid excess smoke, use oils such as grapeseed, canola, or vegetable oil. Oils with a lower smoking point, such as olive oil, will produce more smoke during cooking.

## Using the Accessories

There are 3 accessories included with your grill: the cooking pot, basket, and grill grate. The cooking functions require different accessories, so make sure to use the correct accessory. Follow the recipe instructions or the suggestions given in each function section.

**Always** make sure the cooking pot is properly in place at the bottom of the grill before cooking. [Figure 2.1] The cooking pot is not intended to be used to place food on.

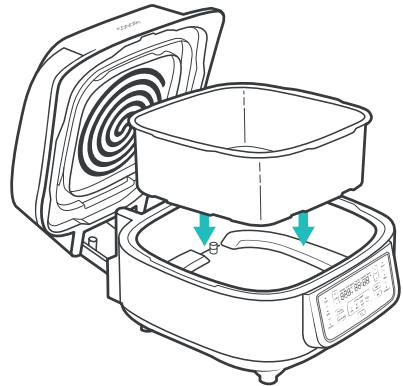

Figure 2.1

## Splatter Guard Assembly

1. Align the splatter guard with the slots on the underside of the grill lid. [Figure 2.2]
2. Use one or both thumbs to gently push the handle of the splatter guard into place.

**Note:** Make sure that the splatter guard is securely in place before cooking.

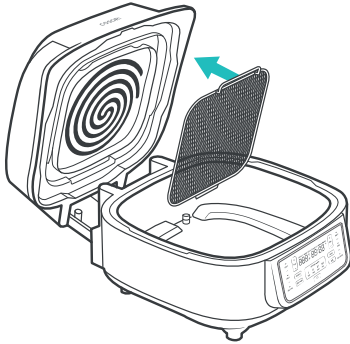

Figure 2.2

## Oil Collector Assembly

1. Align the oil collector with the slot on the back of the unit. [Figure 2.3]
2. Gently push the oil collector into place.

**Note:** Make sure that the oil collector is securely in place before cooking.

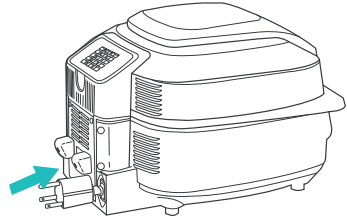

Figure 2.3

## Cooking Functions

Cooking functions are programmed with an ideal time and temperature for cooking certain foods. For more information on each cooking function, see its individual section, or the **Cooking Functions Quick Reference Chart**.

### Customizing Cooking Functions

- You can customize a cooking function's default settings, including time and temperature.
- To change a function's default settings:
  1. When the grill is not cooking or is paused, use the controls to choose the settings you want to change for a function button. You can choose the time, temperature, Preheat setting, Keep Warm setting, and Shake setting.
  2. Press and hold the function button for 3 seconds until the grill beeps 1 time.
- To reset a function to its original default settings:
  1. Make sure the grill is not cooking or is paused.
  2. Without making any changes, press and hold the function button for 8 seconds total.
  3. The grill will beep once after 3 seconds, and then again after 5 more seconds to indicate the temperature and time settings returning to their defaults.

**Note:**

- Press and hold the **PREHEAT** and **SHAKE** button to reset all functions to their default settings.



## Cooking Functions Quick Reference Chart

Name	Use	Suggested Accessory	Range
<b>Air Grill (Low)</b>	<ul style="list-style-type: none"><li>• Grill setting using lowest heat setting and lowest amount of air flow</li><li>• Best used for foods that cook through quickly, such as fish, shrimp, vegetables, fruits, and thin-cut chicken breasts</li></ul>	Grill grate	<b>Temp:</b> 205°–230°C <b>Time:</b> 1 min–30 min
<b>Air Grill (Med)</b>	<ul style="list-style-type: none"><li>• Grill setting using medium-high heat and medium-high air flow</li><li>• Best used for foods that need moderate amounts of time, like burgers, steaks, or pork chops</li></ul>	Grill grate	<b>Temp:</b> 235°–255°C <b>Time:</b> 1 min–30 min

<b>Air Grill (High)</b>	<ul style="list-style-type: none"> <li>• Grill setting using high heat and high air flow</li> <li>• Best used for searing meat</li> </ul>	Grill grate	<b>Temp:</b> 260°–262°C <b>Time:</b> 1 min–30 min
<b>Air Grill (Max)</b>	<ul style="list-style-type: none"> <li>• Grill setting using highest heat and highest air flow</li> <li>• Best used to achieve grill marks on seared meats and other foods</li> </ul>	Grill grate	<b>Temp:</b> 265°C <b>Time:</b> 1 min–30 min
<b>Crisp</b>	<ul style="list-style-type: none"> <li>• Cooks using high heat and high air flow</li> <li>• Best used for crispy foods, such as chicken wings, fries, or bacon</li> </ul>	Basket	<b>Temp:</b> 150°–230°C <b>Time:</b> 1 min–60 min
<b>Broil</b>	<ul style="list-style-type: none"> <li>• Focuses high heat on top of food</li> <li>• Best for melting cheeses, cooking sausages, vegetables, and browning the tops of foods</li> </ul>	Basket Cooking Pot	<b>Temp:</b> 65°–260°C <b>Time:</b> 1 min–4 hr
<b>Roast</b>	<ul style="list-style-type: none"> <li>• Cooks using low to high heat and even airflow to cook food thoroughly</li> <li>• Best used for large or tougher cuts of meats, larger vegetables, and potatoes</li> </ul>	Basket Cooking Pot	Temp: 120°–260°C Time: 1 min–4 hr
<b>Bake</b>	<ul style="list-style-type: none"> <li>• Cooks food evenly using low to medium heat</li> <li>• Best used for breads, cakes, muffins, pies, and cookies</li> </ul>	Basket	<b>Temp:</b> 120°–205°C <b>Time:</b> 1 min–4 hr
<b>Dehydrate</b>	<ul style="list-style-type: none"> <li>• Dries food out over a longer period of time using airflow and low heat</li> <li>• Great for drying out herbs, fruit, or making beef jerky</li> </ul>	Basket	<b>Temp:</b> 40°–90°C <b>Time:</b> 1 min–12 hr

## Preheat Function (“PREHEAT”)

We recommend preheating before placing food inside the grill, unless your grill is already hot. Food will not cook thoroughly without preheating.

1. Plug in. Press  to turn on the grill.
2. Select a cooking preset. The **PREHEAT** function will light up automatically.
3. Optionally, bypass preheating by pressing the **PREHEAT** button.
  - a. If you’ve deselected the Preheat function, place food in the basket before pressing . Press  to start cooking. The display will light up to indicate that your food is cooking.
4. Preheat time is calculated automatically.
  - a. The Preheat function cannot be used with the Dehydrate function.

## Crisp Function (“CRISP”)



This function is ideal for cooking a variety of food, including French fries and chicken wings. Uses high heat and airflow.

1. Place the cooking pot into the base of the grill, followed by the basket.
2. Close the lid, press **⏻**, then press **CRISP**.
3. Optionally, customize the temperature and time.
  - a. Press **TEMP** to control temperature. Use **+/-** to adjust the temperature between 150°–230°C.
  - b. Press **TIME** to control time. Use **+/-** to adjust the time between 1 min–60 min.
  - c. If you would like to bypass preheating, press **PREHEAT** to deselect the preheat function.
4. Optionally select **SHAKE** to add a Shake Reminder.
  - a. If selected, the Shake Reminder will remind you to flip your food halfway through cooking. The grill will beep and **SHAKE** will flash on the display.
  - b. Press **▶||** to resume cooking after flipping your food.
  - c. Be extremely careful when flipping food, as it may be very hot. Use oven mitts or heat-resistant gloves, as well as tongs or other utensils, to flip your food.
- S. Optionally, select **KEEP WARM** to have the Keep Warm function turn on after your food is done cooking.
- T. Press **▶||** to start cooking.
- U. When preheating is complete, the grill will beep and **READY** will flash on the display.
- V. Carefully lift the lid using the handle while wearing oven mitts or heat-resistant gloves and place food into the grill. The grill will automatically pause heating while the lid is open.
  - a. **Do not** overfill the basket.
  - b. For best results, add food up to one-third of the basket's capacity.
- W. Close the lid and resume cooking. The display will light up to indicate that your food is cooking.
- X. When cooking is done, the grill will beep and **END** will show on the display. Carefully remove food and leave the lid open so that the grill can cool.

## Broil Function (“BROIL”)





This function focuses heat on the tops of foods, including cheeses, sausages, and vegetables. Uses high heat.

1. Place the cooking pot into the base of the grill, followed by the basket.
2. Close the lid, press **⏻**, then press **BROIL**.
3. Optionally, customize the temperature and time.
  - a. Press **TEMP** to control temperature. Use **+/-** to adjust the temperature between 65°–260°C.
  - b. Press **TIME** control time. Use **+/-** to adjust the time between 1 min–4 hr.
  - c. If you would like to bypass preheating, press **PREHEAT** to deselect the preheat function.
4. Optionally select **SHAKE** to add a Shake Reminder.
  - a. If selected, the Shake Reminder will remind you to flip your food halfway through cooking. The grill will beep and **SHAKE** will flash on the display.
  - b. Press **▶||** to resume cooking after flipping your food.
  - c. Be extremely careful when flipping food, as it may be very hot. Use oven mitts or heat-resistant gloves, as well as tongs or other utensils, to flip your food.
5. Optionally, select **KEEP WARM** select **KEEP WARM** to have the Keep Warm function turn on after your food is done cooking.
- T. Press **▶||** to start cooking.
- U. When preheating is complete, the grill will beep and **READY** will flash on the display.
- V. Carefully lift the lid using the handle wearing oven mitts or heat-resistant gloves and place food into the grill. The grill will automatically pause heating while the lid is open.
  - a. **Do not** overfill the basket.
  - b. For best results, add food up to one-third of the basket’s capacity.
- W. Close the lid and resume cooking. The display will light up to indicate that your food is cooking.
- X. When cooking is done, the grill will beep and **END** will show on the display. Carefully remove food and leave the lid open so that the grill can cool.

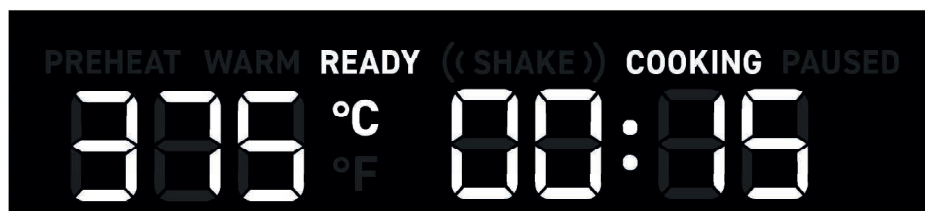
## Roast Function (“ROAST”)





This function cooks food thoroughly and is best used for large or tougher cuts of meats and larger vegetables. Uses low to high heat and even airflow.

1. Place the cooking pot into the base of the grill, followed by the basket.
2. Close the lid, press , then press **ROAST**.
3. Optionally, customize the temperature and time.
  - a. Press **TEMP** to control temperature. Use **+/-** to adjust the temperature between 120°–260°C.
  - b. Press **TIME** to control time. Use **+/-** to adjust the time between 1 min–4 hr.
  - c. If you would like to bypass preheating, press **PREHEAT** to deselect the preheat function.
4. Optionally select **SHAKE** to add a Shake Reminder.
  - a. If selected, the Shake Reminder will remind you to flip your food halfway through cooking. The grill will beep and **SHAKE** will flash on the display.
  - b. Press  to resume cooking after flipping your food.
  - c. Be extremely careful when flipping food, as it may be very hot. Use oven mitts or heat-resistant gloves, as well as tongs or other utensils, to flip your food.
5. Optionally, select **KEEP WARM** to have the Keep Warm function turn on after your food is done cooking.
- T. Press  to start cooking.
- U. When preheating is complete, the grill will beep and **READY** will flash on the display.
- V. Carefully lift the lid using the handle while wearing oven mitts or heat-resistant gloves and place food into the grill. The grill will automatically pause heating while the lid is open.
  - a. **Do not** overfill the basket.
  - b. For best results, add food up to one-third of the basket's capacity.
- W. Close the lid and resume cooking. The display will light up to indicate that your food is cooking.
- X. When cooking is done, the grill will beep and **END** will show on the display. Carefully remove food and leave the lid open so that the grill can cool.

## Bake Function (“BAKE”)



This function is ideal for making breads, cakes, muffins, pies, and cookies. Uses low to medium heat to cook food evenly.

1. Place the cooking pot into the base of the grill, followed by the basket.
2. Close the lid, press , then press **BAKE**.
3. Optionally, customize the temperature and time.
  - a. Press **TEMP** to control temperature. Use **+/-** to adjust the temperature between 120°–205°C.
  - b. Press **TIME** to control time. Use **+/-** to adjust the time between 1 min–4 hr.
  - c. If you would like to bypass preheating, press **PREHEAT** to deselect the preheat function.
4. Optionally select **SHAKE** to add a Shake Reminder.
  - a. If selected, the Shake Reminder will remind you to flip your food halfway through cooking. The grill will beep and **SHAKE** will flash on the display.
  - b. Press  to resume cooking after flipping your food.
  - c. Be extremely careful when flipping food, as it may be very hot. Use oven mitts or heat-resistant gloves, as well as tongs or other utensils, to flip your food.
- S. Optionally, select **KEEP WARM** to have the Keep Warm function turn on after your food is done cooking.
- T. Press  to start cooking.
- U. When preheating is complete, the grill will beep and **READY** will flash on the display.
- V. Carefully lift the lid using the handle while wearing oven mitts or heat-resistant gloves and place food into the grill. The grill will automatically pause heating while the lid is open.
  - a. **Do not** overfill the basket.
  - b. For best results, add food up to one-third of the basket's capacity.
- W. Close the lid and resume cooking. The display will light up to indicate that your food is cooking.
- X. When cooking is done, the grill will beep and **END** will show on the display. Carefully remove food and leave the lid open so that the grill can cool.

## Air Grill Function (“AIR GRILL”)



This function is ideal for cooking open-faced sandwiches, thin cuts of meat (such as bacon), poultry, fish, sausages, and vegetables.



Can also be used to brown the tops of casseroles, gratins, and desserts.

1. Place the cooking pot into the base of the grill, followed by the grill grate.
2. Close the lid, press **⏻**, then press **AIR GRILL** or directly select the Low, Medium, High, or Max heat setting.
3. Optionally, customize the temperature and time.
  - a. Press **TEMP** to control temperature. Use **+/-** to adjust the temperature according to the range for your selected heat setting.
  - b. Press **TIME** to control time. Use **+/-** to adjust the time between 1 min–30 min.
  - c. If you would like to bypass preheating, press **PREHEAT** to deselect the preheat function.
  - d. Save custom settings by pressing and holding **AIR GRILL** for 3 seconds.
  - e. Reset to the default function settings by pressing and holding **AIR GRILL** for 8 seconds.
4. Optionally select **SHAKE** to add a Shake Reminder.
  - a. If selected, the Shake Reminder will remind you to flip your food halfway through cooking. The grill will beep and **SHAKE** will flash on the display.
  - b. Press **▶▶** to resume cooking after flipping your food.
  - c. Be extremely careful when flipping food, as it may be very hot. Use oven mitts or heat-resistant gloves, as well as tongs or other utensils, to flip your food.
5. Optionally, select **KEEP WARM** to have the Keep Warm function turn on after your food is done cooking.
- T. Press **▶▶** to start cooking.
- U. When preheating is complete, the grill will beep and **READY** will flash on the display.
- V. Carefully lift the lid using the handle while wearing oven mitts or heat-resistant gloves and place food into the grill. The grill will automatically pause heating while the lid is open.
  - a. For best results, add food in a single layer.
- W. Close the lid and resume cooking. The display will light up to indicate that your food is cooking.
- X. When cooking is done, the grill will beep and **END** will show on the display. Carefully remove food and leave the lid open so that the grill can cool.

## Dehydrate Function (“DEHYDRATE”)



This function combines low and stable heat with steady airflow to evenly dry out foods without cooking. Ideal for drying herbs, fruit, or making beef jerky.

1. Place the cooking pot into the base of the grill, followed by the basket.
2. Place food into the basket.
  - a. For best results, add food in a single layer.
3. Close the lid, press , then press **DEHYDRATE**.
  - a. Press **TEMP** to control temperature. Use **+/-** to adjust the temperature between 40°–90°C.
  - b. Press **TIME** to control time. Use **+/-** to adjust the time between 1 min–12 hr.
4. Optionally, customize the temperature and time.
5. Press  to start cooking.
6. When cooking is done, the grill will beep and **END** will show on the display. Carefully remove food and leave the lid open so that the grill can cool.

## Shaking Food

### Shake Reminder

- The Shake Reminder is designed to remind you to check on your food, usually to flip or mix it. Press **SHAKE** to turn on the Shake Reminder.
- You can use the Shake Reminder with any cooking function except Dehydrate. We especially recommend using the Shake Reminder with the **Crisp** function (see page 16).
- The Shake Reminder will appear halfway through cooking time.
- If **SHAKE** is pressed during cooking, it will appear halfway through the remaining cooking time.
- The Shake Reminder will alert you with a beep, and "**(SHAKE)**" will blink on the display.
- The Shake Reminder will turn off once you open the grill lid.
- The Shake Reminder will turn off after 2 minutes if there is no activity.

### What to Shake

- Small foods that are stacked, such as fries or nuggets, will usually need mixing or flipping. Otherwise, this food may not be crispy or evenly cooked.
- You can flip other food, such as steak, to ensure even browning.

### How to Shake

- Add the Shake Reminder to your cooking program by pressing **SHAKE**.
- When the Shake Reminder appears, carefully lift the lid using the handle wearing oven mitts or heat-resistant gloves. The grill will automatically pause heating while the lid is open.
- Use tongs or other utensils to mix or flip the food.
- When you close the lid, cooking will automatically resume.
- Avoid mixing or flipping food longer than 30 seconds, as the grill may start to cool down.

# CARE & MAINTENANCE

---

Clean grill accessories (including cooking pot, splatter guard, etc.) and grill interior after every use.

1. Before cleaning, turn off and unplug the grill, and allow it to cool completely. Open the lid for faster cooling.
2. Apply non-abrasive liquid cleanser or a mild spray solution to a soft, damp cloth or sponge (not the grill surface) and wipe all parts of the grill. **Do not** use a dry cloth on the display screen, or it may be scratched.
3. To remove the splatter guard for cleaning, remove the splatter guard from the underside of the lid by pulling the handle down and gently pressing on the mesh. [Figure 3.1].

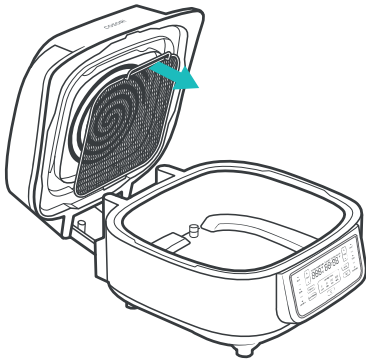

Figure 3.1

4. Clean the splatter guard using a non-abrasive liquid cleanser or a mild spray solution and soft, damp cloth or sponge.
5. To remove the oil collector for cleaning, pull the oil collector carefully from the back of the grill.

**Note:** The oil and oil collector will be hot after cooking. Allow the grill to cool before cleaning the oil collector.

6. Carefully dispose of oil, then clean the empty oil collector using a non-abrasive liquid cleanser or a mild spray solution and soft, damp cloth or sponge. Allow to dry completely before replacing into grill.
7. Remove the filter cover and take out the filter. Clean using a non-abrasive liquid cleanser or a mild spray solution and a soft, damp cloth or sponge to wipe the outer surface of the filter.

**Note:** The filter and filter cover will be hot after cooking. Allow the grill to cool before cleaning the filter.

8. Let all surfaces dry completely before plugging in or turning on the grill.

**Note:** The cooking pot, basket, grill grate, and splatter guard are dishwasher safe.

## Cleaning the Splatter Guard

Clean the splatter guard after every use to prevent grease or food residue from becoming permanently stuck to the mesh.

1. Optionally, soak the splatter guard overnight to help soften grease and residues.
2. Use the cleaning brush to remove grease from the edges of the guard.

## Deep Clean

Deep clean the splatter guard to remove excess grease and food residue.

1. Deep clean the splatter guard by placing it in a pot of boiling water for 10 minutes.
2. After boiling, carefully remove the splatter guard and rinse with room temperature water.
3. Allow to dry completely before using again.

## Storage

1. Clean and dry the grill and all accessories.
2. Place the cooking pot into the grill.
3. Place the grill grate into the grill base, on top of the cooking pot.
4. Place the basket into the grill base, on top of the grill grate. All accessories should be stacked on top of one another.
5. Close the lid.
6. Store the grill in an upright position.  
**Do not** store anything on top.

# TROUBLESHOOTING

Problem	Possible Solution
The grill will not turn on.	Make sure the grill is plugged in.
The grill has a plastic smell.	New grills may have a plastic smell. This is normal. Follow the instructions for a <b>Test Run</b> to get rid of the plastic smell (page 10).
Food is not completely cooked.	Increase cooking temperature or time.
	Place smaller batches of food into the grill.
Food is overcooked or burned.	Decrease cooking temperature or time.
	Make sure food items are not too large and are not touching the heating element.
Food is cooked unevenly.	Preheat the grill manually by using the Preheat function (page 18).
	Make sure food items are not too closely packed into the grill. We recommend filling the grill to one-third of its capacity.
	Spread food into an even layer before cooking
	Use the Shake Reminder and mix or flip food halfway through cooking (see <b>Shaking Food</b> , page 22).
Food is not crispy after grilling.	Spraying or brushing a small amount of oil on foods prior to cooking can increase crispiness.
White smoke or steam is coming out of the grill.	The grill may produce some white smoke or steam during cooking. This is normal.
	During first use, dust from the packing process may cause white smoke. This is normal for air grills and many other kitchen appliances. To eliminate any dust, see <b>Test Run</b> (page 10).
	Excess oil or fatty foods may produce white smoke. Make sure the inside of the grill is cleaned properly and isn't greasy.
	The filter may need to be replaced. We recommend replacing the filter every 6 months. Contact <b>Customer Support</b> (see page 26).
	Using fats or oils with a low smoking point such as coconut, olive, or vegetable oil, may produce white smoke during cooking.
Dark smoke is coming out of the grill.	Immediately press <b>▶  </b> and unplug your grill. Food is burning. Wait for smoke to clear before opening the lid.

<p><b>A thermometer shows that the grill temperature is different from the grill setting.</b></p>	<p>Commonly used thermometers usually have low sensitivity and take over 10 minutes to measure the correct temperature. This will not affect cooking.</p>
<p><b>Display shows Error Code "E1".</b></p>	<p>There is an open circuit in the temperature monitor. Contact <b>Customer Support</b></p>
<p><b>Display shows Error Code "E2".</b></p>	<p>There is a short circuit in the temperature monitor. Contact <b>Customer Support</b></p>
<p><b>Display shows Error Code "E3".</b></p>	<p>The grill is overheating. Unplug it and allow it to cool down.</p>
<p><b>Display shows Error Code "E4" or "E5".</b></p>	<p>Make sure your grill is being used with the correct 220V-240V, 50Hz electrical system.</p>

**If your problem is not listed, please contact Customer support.**  
Visit [www.allianceair.co.za](http://www.allianceair.co.za)